

CONTINUOUS POWER IN YOUR CONTROL



**Power**KEM



# Simply Reliable Solutions to Power Quality Issues

Banks, Data Centers, Telecoms, Airports, Manufacturing Processes & Major Research Projects, in fact all installations where continuous running is required, demand a filtered, continuous and sustainable power supply solution.

HITEC Power Protection can guarantee the availability of high quality power with our PowerKEM rotary UPS (Uninterruptible Power Supply). We have over 60 years' experience in the design and manufacture of rotary

UPS systems. HITEC Power Protection provides a high level of reliability and efficiency ensuring total protection of essential electrical loads and low cost of ownership for the lifetime of your facility.

Our team of experienced engineers and technicians will partner with you to identify your needs, develop an optimal design and implement the system in your facility.



## Simplicity. Reliability. Low Cost of Ownership.

### Technical advantages of the PowerKEM:

Standard synchronous generator (no special windings) simple steel flywheel and low speed shaft offering extended bearing life with very low maintenance.

The PowerKEM is based upon simple, efficient, conventional electrical and mechanical components. Its simplicity leads to very high reliability and low service costs which, added to the energy saved by the low UPS losses and no requirement for air-conditioning, produces a very low Total Cost of Ownership.

The system consists of a standard synchronous generator with no special windings and a simple steel flywheel. The low speed shaft extends bearing life and reduces maintenance. The PowerKEM machine is very robust as critical functions do not use fragile components such as power electronics, power capacitors, electro-chemical batteries, active magnetic bearings, electro-mechanical or mechanical friction clutches.

In normal operation the PowerKEM protects the electrical load from power quality problems eliminating harmonics, flicker, voltage spikes and sags. This power quality protection prevents wear on your facilities infrastructure – including damage to motors and pumps, and reduces the maintenance downtime necessary to repair or replace such assets. These issues can be over 95% of power problems faced by your facility each year.

During mains failure the PowerKEM protects the load and maintains the power supply at the precise voltage and frequency by supplying energy to the alternator from the Accumulator without need for electronic power conversion.

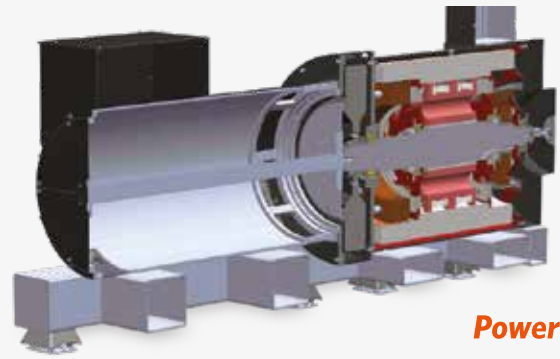

**PowerKEM**

Whilst these 'blackout' events are fewer in number, for organizations where power is always required during operation, interruption of mains electricity leading to loss of production (including restart time), wastage of part processed materials and a dented reputation could be very costly.

Under extended mains failure, the load is automatically transferred to your chosen back-up energy source, usually a diesel genset. Once a stable mains supply returns the PowerKEM will safely transfer the load back and be ready to act again.

Applications of Uninterruptible Power Supply (UPS) systems have traditionally been in Air Traffic Control, data centers, large financial organizations and telecoms providers.

Today, as manufacturing becomes more sophisticated and especially where mains (utility) power is not always 'clean' and reliable, UPS systems are being employed in food and beverage production, mining, chemicals and metals processing. Other services such as hospitals, broadcasting, major retail and large stadiums also require access to uninterrupted power at all times as they operate. The PowerKEM is reliably and efficiently employed in these and many other applications worldwide.

## Single Module

### PowerKEM with Genset for continuous power supply (Dynamic UPS)

A single module is the basic building block for larger scale systems. However, single modules are sometimes deployed where voltage regulation and protection against short disturbances ("transients") are a prime concern and where a lower level of resiliency is acceptable. In 'n+0' configurations the power of the RUPS matches the power required by the "No-Break" load (guarantees that power is available 99.95% of the time). Such 'n+0' solutions are very efficient, have a lower CapEx cost and are suited to operations where downtime is to be avoided and mains power quality is inconsistent.

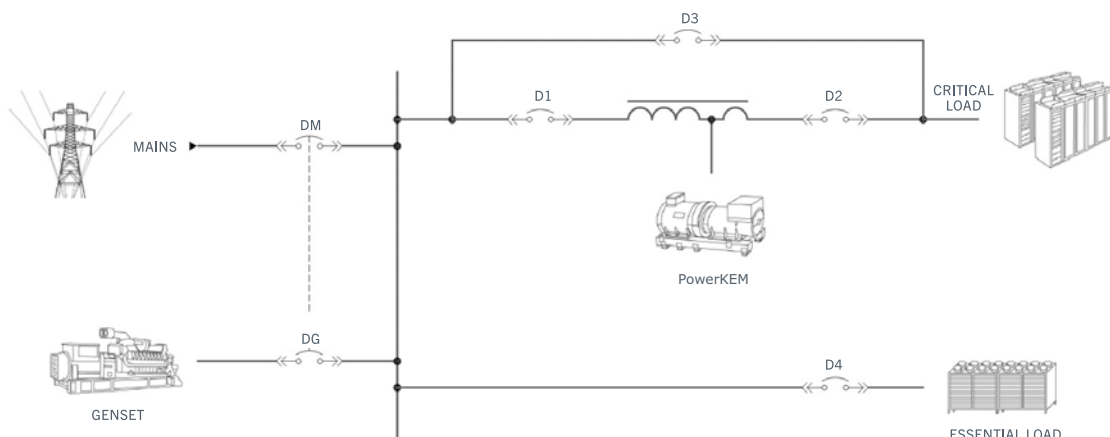

## Feature

## Benefit

### Outstanding voltage conditioning

- Protects equipment against mains voltage fluctuations, sags and microcuts
- Naturally compensates power factor without need for PFC equipment
- Filters load harmonics and voltage harmonics from mains
- Eliminates flicker

### Total power failure protection

- Sustainable continuous power supply
- Ride-through mode covers 90% of mains failures without genset start
- Flexible Dynamic UPS solution when configured with standard genset

### Robust rotary technology

- Conventional electrical / mechanical machine
- High reliability
- Low cost maintenance

### High efficiency

- Energy saving
- Unrivaled low Total Cost of Ownership (TCO)
- Green technology

### High short-circuit power

- Fast fault-clearing capacity ensuring protections selectivity
- Suitable for high peak currents (motors and mechanical loads)
- Suitable for high crest factors (non-linear loads)

### Modular and resilient "Plug & Run" paralleling

- Flexibility from day one
- Scalability for future extension
- High resilience thanks to full redundancy without single point of failure
- Ideal for Tier III / Tier IV applications (Uptime Institute)

### Easy interfacing

- User-friendly digital display (HMI)
- Basic interface via simple contacts
- Powerful communication features :
  - SCADA / BMS interface via MODBUS RTU/TCP
  - Internet access
  - PC supervision
  - Remote monitoring, alarming and paging features

### Low maintenance

- Simple maintenance operations
- Unaffected up-time: no need to stop UPS during maintenance
- Automatic Lubrication System for maximum reliability and lowest TCO

## Parallel Installation

Employing redundant modules (n+1) in a parallel configuration builds extra resiliency into your power protection system. It means that even if multiple incidents occur at the same time, for instance, the mains fails whilst the diesel genset is being maintained, the 'redundant module' can automatically protect the load and ensure that your operations continue unaffected.

This approach pushes guaranteed power availability to levels nearer the 99.999% (5 nines) which is regarded as the 'holy grail' of uptime. Such a system is essential only where the load must never be unprotected - data centers, banks and telecoms with strict service level contracts insist on this and even higher levels of resiliency.

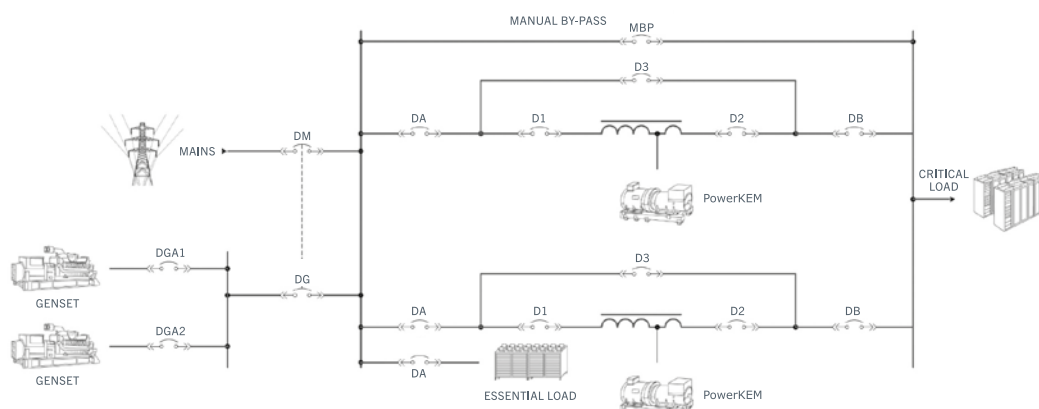

## Medium Voltage

Recognition of the advantages of Medium Voltage (MV) systems in facilities with high power requirements is growing. The benefits include: ease of power distribution, lower TCO, improved safety, reduced maintenance / greater reliability, enhanced flexibility in current and future power infrastructure and improved green credentials with lower embodied energy and lower energy usage.

**HITEC Power Protection can provide Dynamic UPS systems that will support MV in your facility, delivering high quality, continuous MV power to your operation.**

Using medium voltage solutions may allow your facility design to minimize cabling, reducing capital expenditure and the impact of your facility on the environment. Whether you employ a low voltage or medium voltage design, our simplified approach minimizes embodied energy costs and maximizes operating efficiency.

**HITEC Power Protection can offer a wealth of configurations and options including Turnkey System Solutions, Medium Voltage Installations, Containerization and Rental UPS.**



## PowerKEM Range

TYPE	POWER		
		kVA	kW
50 Hz or 60 Hz			
PowerKEM400	50/60	400	320
PowerKEM500	50/60	500	400
PowerKEM500HP	50/60	500	500
PowerKEM630	50/60	630	504
PowerKEM800	50/60	800	640
PowerKEM1000	50/60	1000	800

## Green Technology

Our highly efficient UPS supports your aims to minimize your environmental impact and mitigate the effects of rising energy costs in the future. Our PowerKEM design, almost all steel and copper, ensures that it is over 99.97% recyclable.

- No batteries - no need for expensive replacement cycle / no costly disposal of hazardous materials
- No air conditioning required - providing a/c for battery rooms is a significant cost and impacts the environment
- Dynamic Autonomy Control (DAC): Automatic speed adaptation for optimum efficiency at partial load with FULL critical load protection
- 91% of all voltage interruptions last less than 1 second (European urban locations) the PowerKEM protects the load without generator starts\*.

\*This is configurable to maximize PowerKEM's power output or compensate for short interruptions.

## Total Solution Provider

We promote long-term service partnerships that deliver quality, reliability and value throughout the lifecycle of your equipment. Our customized service solutions encompass an advanced remote monitoring platform, performance reporting, service inspections, maintenance, training and service consultation. Our Helpdesk is dedicated to providing timely, high quality support to all of our customers Worldwide, 24x7x365. We provide the partnership that fits your need and ensures that "Power is in your Control".



[hitec-ups.com](http://hitec-ups.com)



EFFICIENCY



COMPACT



CONNECTIVITY



FUNCTIONALITY



MAINTAINABILITY



QUALITY



SERVICE